

Geobruigg Jubilee Conference
Bad Ragaz, Switzerland, 20th June 2001

**From the timber fence to the
high-energy net. Developments in rock-
fall protection from the origins to
the present.**

Extract from a presentation by Dr. Raymund M. Spang*
and Eng. grad. Reinhold Bolliger** / *Dr. Spang Geotechnical Consultants Ltd.,
Witten, Germany / **Formerly of Brugg Drahtseil AG, Brugg/Switzerland

© Fatzer AG
GEOBRUGG Protection Systems
CH-8590 Romanshorn
Phone +41 71 466 81 55
Fax +41 71 466 81 50
Email info@geobruigg.com
www.geobruigg.com

Summary

The history of rockfall protection, influenced to a decisive degree by a member of the Brugg Group, is presented for the first time on the 50th anniversary of the invention of wire rope nets by that company. To start with, the origin of rockfall protection within avalanche protection is dealt with. The developments from the timber to the steel post, from nets featuring rectangular meshes to the ring net, from the single- to the twin-rope execution, from single footings to foundations by means of micro-piles and from galvanizing to the Galfan corrosion protection are described. The presently achieved level is explained. Finally, emerging development trends towards yet higher energy absorptions, numerical dimensioning methods and European system certifications are looked at. Focal point of the presentation is the development of high-energy protective fences.

Introduction

On the 50th anniversary of the invention of wire rope nets by a company of the Brugg Group it was thought worthwhile to compile the history of rockfall fences, all the more so since no publication on this topic exists to date. While avalanche protection can be traced back as far as 1518, a corresponding need for protection against the risks of rockfall developed presumably from 1834 only, i.e. the beginning of railway construction. It must be noted that, in the 50 years between 1835 and 1885, 195,833 km of railway lines were laid in Europe and 487,343 km in the whole world, with a considerable portion running through mountainous regions. With the track-bound vehicles moving very fast in comparison with horse-drawn coaches, its long braking distance and a substantially higher number of potentially endangered passengers, the demands for safe and unobstructed routes increased very rapidly. When railway construction in Germany reached its peak between 1870 and 1880, a large number of textbooks which remain worth reading to this day had already been published on almost all geotechnical questions which came up in this context. Protection against rockfall, however, is not mentioned. Up to the early nineteen-fifties one relied primarily on railway-specific materials, i.e. rigid walls built from rails and wooden sleepers, as precautions against rockfall.

First Applications

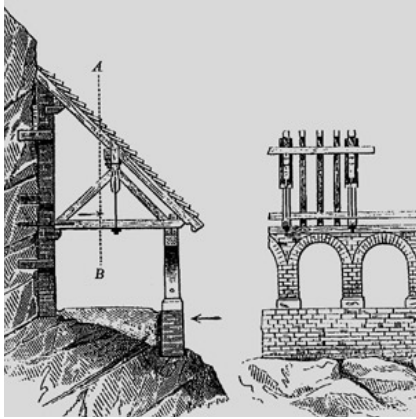

Fig. 1



Fig. 2



Fig. 3

In his textbook on "Road Construction", chapter „Various devices and systems to be counted among the engineering structures“, AHLBURG (1870, 315) mentions that „special installations opposing the sliding off of rock débris formed by the weathering processes are no doubt required to protect traffic along mountain roads.“ His findings are illustrated by the gallery shown in Fig. 1. No further protection possibilities are listed.

The use of wire rope nets started in avalanche protection with triangular nets featuring rectangular meshes, initially mounted on timber posts and subsequently on steel posts. (Fig. 2). The mesh size was 20 x 20 cm. The first application was in 1951 on the Schafberg at Pontresina, in the Engadine valley/Switzerland. In 1952, the then Kabelwerke Brugg were granted a patent on this new type of protection from avalanches. Wire rope nets had already previously been used for protection purposes in blasting operations. At the outset the nets were erected individually (Fig. 3). The idea of the series structures was only developed in the years after by Professor HÄFELI who taught at The Swiss Federal Institute of Technology (ETH) in Zürich and who initiated dimensioning methods for avalanche prevention structures of wire rope nets which have remained valid to this day.

Experience showed that avalanche prevention structures were time and again exposed to rockfall and stood up to it during the snow-free period. This observation prompted BINDSCHÄDLER, an employee of high merit of Kabelwerke Brugg AG, to use wire rope nets also for protection against original rockfall. The world's first structure of wire rope nets against rockfall was erected in 1958 at Brusio, Southern Switzerland, for the overhead power transmission lines Campocologno - Cavaglia. The construction based on rectangular nets measuring 3 x 5 m stood 5 m high, i.e. high even by today's standards. It was placed on a retaining wall and tensioned by steel girders. The second rockfall protection structure followed already in 1959 near Ardez in the Lower Engadine, and was also erected on top of a supporting wall.



Fig. 4

An impressive example for the protective effectiveness of avalanche constructions also against rockfall became evident in 1961 with the avalanche prevention structure erected in 1954 on the Stotzigberg, Vasön in the Canton of St. Gallen/Switzerland. Rocks of a total volume of approx. 3 cubic meters were caught and held without problems (Fig. 4). Near Pfäfers in the same Canton, wire rope nets were installed in 1959 to protect a road from falling ice.

First field tests



Fig. 5

Dimensioning methods which had become standard in avalanche protection were not yet available for rockfall mitigation. The energy which such constructions could absorb was not yet known. This led to the first systematic rockfall tests in 1962. At Brunnen on Lake Lucerne, rocks of 520 N were dropped from a cereal silo from a height of 45 m with a, by current standards, minimal energy of 23 kJ into wire rope nets secured by nylon ropes horizontally in a steel frame (Fig.5). Despite the successful trials - the net coped with the rocks without suffering damage - the Axen road at the location in question was protected by a very expensive gallery that is still in place today.

In 1968, at the suggestion of the BLS Railway Company, rocks of up to 10 kN were rolled down a slope into a rockfall protection structure consisting of three sections of diagonal wire rope nets (Fig. 6). The energy absorption capacity specified for these structures was still low. The involved persons came to the insight, however, that a desirable increase of the energy absorption, expressed by the mechanical work W effected by the rockfall on the system, at a limited force absorption F of the system could only be achieved with maximum possible displacement paths s in accordance with the following equation: $W = F \times s$

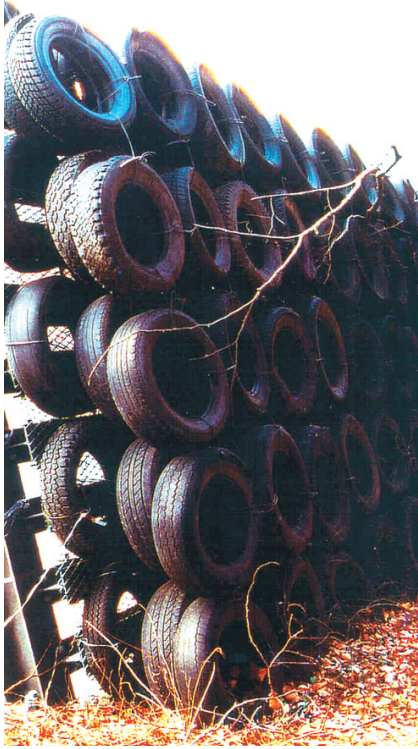

Fig. 6



Fig. 7

The elongation at rupture of 2.5 to 3 % of normal steel ropes was not sufficient for these purposes. One succeeded eventually in developing wires with an elongation at rupture of up to 15 %. The mechanical strengths were too low, however, so that the effect remained low, too. The breakthrough came only with brake elements. These enabled braking distances which were practically only limited by the retention of the catchment effect of the structure. To come right away to the magnitude which developments have reached in the meantime: In current tests carried out at the new test site at Walenstadt / Switzerland, a block of 96 kN dropping free from a height of 32 m was stopped completely after a deformation path of 7,2 m without serious damage to the protection system. Hereby the kinetic energy determined by inclusion of the deformation path amounted to 3,000 kJ. A world record no doubt! For contrast, the system shown in Fig. 6 would only have absorbed a fraction of this on account of its very massive execution.

Systematic rockfall trials aiming at the development of systems with a superior working capacity were carried out from 1975 on the company site of Kabelwerke Brugg AG at Birr in cooperation with the engineering office HEIERLI of Zürich (HEIERLI, 1976).

Hereby concrete blocks of up to 10 kN were dropped freely from a truck-mounted crane from a height of up to 20 m into horizontally tensioned wire rope nets. The bearing frame consisted of steel girders (Fig. 7). Braking elements were finally used for the first time in these tests.

Braking elements

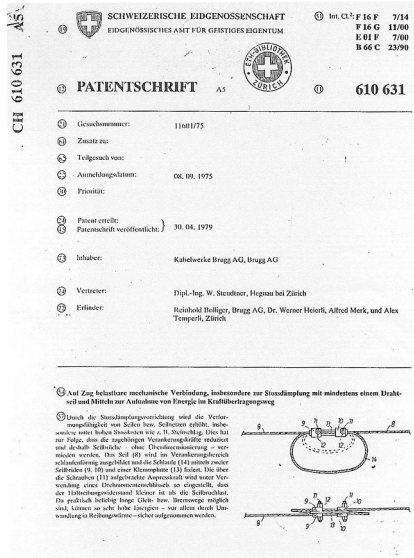

Fig. 8

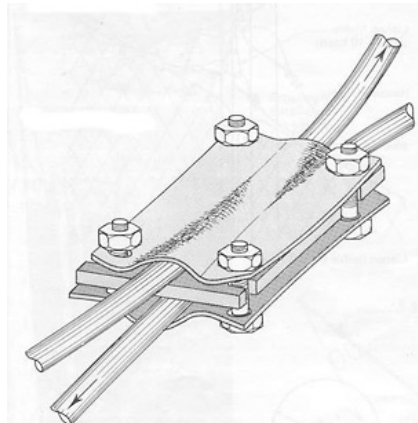

Fig. 9

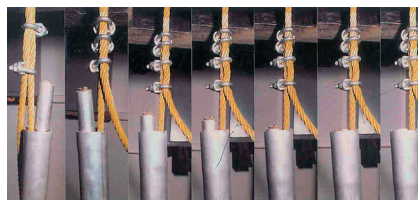

Fig. 10a



Fig. 10b

Braking elements allowed the desired major displacements with simultaneous energy dissipation by friction work. It was the first time that braking elements with wire rope nets were used for rockfall mitigation. BOLLIGER and HEIERLI were able to apply for a patent for these rope brakes in 1975 (Fig. 8). Braking elements of various executions are meanwhile an integral part of most rockfall protection fences available on the market. The following presentation shows how different these braking elements can be.

1979 there are reports from France that 3 steel plates arranged on top of each other were used as braking elements (Fig.9). At a braking distance of 6 m a nearly linear energy absorption of 160 kJ over the braking distance was reported.

A Swiss Company has been using a plate brake developed by it as a braking element since 1985. Here the wire rope is threaded through bores in a steel plate. At braking distances between 1 and 1.5 m the energy absorption amounts to 50 and 75 kJ, respectively.

An Italian manufacturer developed a braking element with which a steel tube is widened by a cone. According to the producer this deformation brake absorbs 50 kJ over an unknown distance (Fig10).



Fig. 11a



Fig. 11b

In 1991, FATZER AG was granted a patent on the brake ring named SIFA which is now used in a modified execution by GEOBRUGG. Here the rope passes through a bent pipe of ring shape. Originally the two ends of the pipe were welded together by means of a steel plate, while they are now compressed by an aluminium sleeve (Fig. 11). This aluminium sleeve with which the two pipe ends are connected prevents the separation of the ring due to the pair of forces out of unequal planes from the ropes. Additionally it enhances the energy dissipation capacity of the brake ring considerably. The following advantages characterized the new brake ring which replaced Brugg's rope brake after the two companies merged to form Geobrugg:

- The brake rings had a substantially lower tolerance in their response behavior.
- After installation in the rope the brake rings required only a minor effort to be shifted.
- On responding of the brake ring the rope was not injured by the pipe wall. Its load at rupture remained intact also in case of major shifting distances.

The energy absorption of the brake rings has not changed substantially since the beginnings. Depending on the rope diameter it amounts to between 70 and 140 kJ. The assumption that the energy absorption of a rockfall protection system might be increased to any level by arranging a sufficient number of brake elements in series is unfortunately wrong. This is so because brake elements in neighboring sections cannot be activated to any distance from the point of impact due to the system's inertia.

An important question in the context of maintenance is from when on a brake element must be exchanged after a rockfall. This depends on the shifting distance that is still available and on the magnitude of further rockfalls to be expected in relation to the dimensioning event. Brake elements must of course only respond within the range of the dimensioning event in the first place, while the system alone must cope elastically with smaller events.

Patent law has always permitted to patent parts of the system only, but not the complete system. To this extent there has not been a lack of copiers with whom there have also been some cases of patent disputes on account of patented parts. As opposed to different competitors which were mostly either dealers, developers or producers exclusively, both Kabelwerke Brugg AG and Fatzer AG, now under the common GEOBRUGG roof, uncompromisingly followed the road of an own development, own production and own marketing. Production facilities in the USA, China and since recently also in Japan are clear evidence of this.

Wire rope nets



Fig. 12a



Fig. 12b



Fig. 12c

While rectangular nets were used initially for avalanche prevention structures, one soon recognized the advantages of triangle-shaped nets. They were easier to calculate as far as protection against avalanches was concerned and adjusted more readily to uneven terrain. Kabelwerke Brugg AG used rectangular nets exclusively right from the start for rockfall protection purposes, whereby the nets did not mandatorily have to be rectangular for adaptation to uneven terrain. Trapezoidal layouts were also suitable. In a brochure of an Austrian company, on the other hand, triangular nets for both avalanche and rockfall protection were still promoted in 1973.

The first wire rope nets for avalanche and rockfall protection were of the parallel braided type, while diagonally braided nets were used later on. Both types were made by hand. The endless mesh rope was entwined with a circumferential boundary rope. Diagonal nets were already used in the 1975 drop tests at Birr/Switzerland. Ring nets which have meanwhile completely displaced the diagonal nets for rockfall protection systems at GEOBRUGG were added from 1990 onwards (Fig. 12). Diagonal nets are still in use by a Swiss competitor, enabling at present energy absorptions up to 2,000 kJ.

The first ring nets consisted of spliced rings and originated from marine stocks of the nineteen-forties, when they were used to guard harbors against submarine attacks. Their drawback was the difficult-to-remove anti-corrosion agent Cosmoline which led to disposal problems in case of removal by solvents. If not removed beforehand, the agent caused problems on handling of the sticky and rather smelly nets.

Due to their 6 neighbor rings the submarine nets were very heavy. As the mass had to be accelerated on impact of blocks, they were superior to the diagonal nets in the energy absorption. Stocks were used up, however, and no further submarine nets were produced any more worldwide. New approaches had to be found. Splicing as a cumbersome and expensive manual task was at first replaced by rope constructions with compression sleeves of steel. First new ring nets were produced by Kabelwerke Brugg AG in 1982 – 1984 to protect water dams from torpedoes, in the Middle East.

To save material, nets with only 4 neighbor rings were finally developed. The six-fold connected nets have approximately 20 % more rings per m² than the four-fold connected ones. For the latter type, Fatzer AG was awarded a patent in 1993. Real progress was at last achieved in 1996 with the development of a production line which permits to produce the ring nets fully automatically by means of robots. This made production considerably more efficient and the price of the ring nets became competitive against the one of the diagonal nets.

For the CAN system (patent by Fatzer AG), 6-fold connected submarine nets are being used to this day.

The tests of 1989 in California demonstrated that, despite the high flexibility and strength of the wire rope nets, a wire mesh placed on the upslope side serves not only to retain rocks below the mesh size of the wire rope net as was already evident

from the drop tests of 1975 at Birr, but that it is an indispensable supplement also to absorb and distribute the rotation energy.

Subject to changes was not only the geometry of the nets, but also the material used for them. In principle stranded ropes were used for the diagonal nets and spiral ropes for the ring nets. From 1996 onwards the ring nets were made from wires of rope wire compressed to a bundle of parallel wires. The wire bundles were easier to produce.

Interesting parallel developments took place in France, where nets of nylon tape were initially used for avalanche prevention purposes and later also for rockfall protection. They did not prove effective, however, and for this reason have disappeared from the market.

Rope clamps

With the rectangular nets the mesh ropes were originally knotted at the cross points. Later on, the knots applicable to thin ropes only were replaced by wire rope clamps and above all by cross clamps. The first field tests with rocks rolled down a hill at Big Sur, California, demonstrated that the cross clamps used by Kabelwerke Brugg AG were not stable enough. This is why, from 1989, they were replaced by the slotted cross clamps with frictional connection which are still in use now.

A Swiss competitor was using since 1985 nets with screwed rope crossings. Screwed rope clamps with plates were used until 1995, when the change to frictionally connecting clamps took place.

To secure rope end connections, commercially available U-bolt rope clips were and are used in the quantities specified by DIN 1142 to suit the rope diameter.

Net fastening



Fig. 13

As customary in avalanche protection, the first nets were fastened directly to the posts (Fig. 13). This selective fastening revealed to be a weak point, whereby the introduction of the rope brakes required a different type of fastening also. The nets were subsequently fastened by means of horizontal support ropes between the posts. Fastening was initially by rope clamps or a seam rope.

Guidance of the support rope was simple at first. The top support rope ran from one lateral anchorage of the section in question over the first post head with a rope guidance inserted there for the purpose, to the anchorage at the opposite end, while the lower support rope ran between the outer posts. The brake elements were incorporated in the support ropes. This, however, restricted the movability of the brakes and caused damage to the net fastening.

As a result of strong competition in 1988 the patented twin-rope guidance which relies on 2 parallel running support ropes at top and bottom each was generally used. The net elements are alternately fastened to one rope, section-by-section, while the brake elements are fastened to the free section of rope in each case. This means that nets and rope brakes are movable independent of each other. This permitted to increase the energy absorption capacity by a factor of four to five with dimensions otherwise remaining the same.

Kabelwerke Brugg AG had taken a different approach at the Bannwald Altorf project in 1978, at first. Within the sections, the nets were fastened one half to one and the other half to the other rope. Here again the rope brakes were placed on the free part in each case. However, instead of running parallel, the ropes were crossed. The crossing point was secured by a clamp. This twin-rope guidance had its origin in an idea of PETITPIERRE, formerly of Kabelwerke Brugg AG, and was used for the first time in 1978 in the protected forest shielding the town of Altdorf/Switzerland. GEOBRUGG developed this parallel twin-rope guidance further to provide the system with maximum elasticity and at the same time with a maximum remaining effective height after it had been hit. The split in halves has been abandoned and the nets are now fastened on both of the two parallel-running support ropes, up to the brake elements arranged at the posts. From there they are exclusively fixed at the rope running in front of the post. Hereby the support rope without brake elements and with the net fastened to it runs downslope of the post, while the rope with the brake elements runs over the rope guidance on the post. This means that one rope with the brake elements is held at the post, while the other is not. The rope with the brake elements can move freely and thereby, as desired, react without restriction to impacts in neighboring sections.

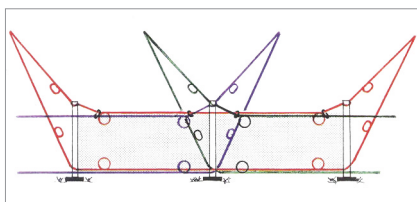

Fig. 14

Fig. 14 shows a rope guidance used by Fatzler AG before 1992, including back-anchoring of the posts.

Posts



Fig. 15

In the origins of avalanche prevention, as already mentioned, the posts were made of wood. Steel posts, however, were already used in the first applications for rockfall protection purposes. Tubular posts were resorted to in the first application of 1958 at Brusio. Profiled supports were used already at an early stage. Rail profiles were in use initially, then IPB and later on mainly HEB profiles, while the application of tubular posts continued in a few types of structures. Beyond this, toggle-lever posts with tension or pressure struts are used for special applications and with particular systems.

To minimize the damage in case of posts being hit, the posts at Brusio were already equipped with cardan joints, i.e. they acted statically as swivel posts (Fig. 15). So-called rigid joints were used from 1978, featuring a predetermined breaking point in the form of a plate fastened to the post by means of two bolts. The plate bent when appropriate, i.e. in an event which the foundation of the post and the post itself could still absorb without suffering damage. Such a rigid joint was used for the first time in Goppenstein/Switzerland on the South Ramp of the Lötschberg railway line.

Today, mostly posts feature a genuine joint with, e.g. in the case of GEOBRUGG, an intermediate piece made from two pieces of steel sheet allowing a spring effect transverse to the plane of the post. Failure at the right time of this intermediate piece serves to avoid damage to the post and its foundation.

Post foundation

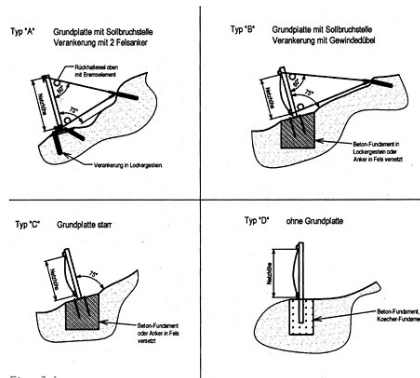

Fig. 16

To the extent that they were not placed on supporting walls or reinforced concrete structures, the posts featured individual footings of concrete. By means of heavy-duty dowels the post was screwed to the foundation over a base plate. Since about 1989 one normally renounces on the individual foundation which is elaborate and expensive particularly in the case of unstable substrates. The foundation now consists of a base plate which is fixed in position by 2 nails. As a rule the upslope nail is inclined at an angle of 45° against the vertical upslope, while the downslope one is vertical of micro-pile execution. This means that the upslope nail is subjected to more tension, the downslope one to shear and normal stress. Both, however, are also subjected to considerable bending moments at the head, which is the reason why the part close to the surface can now also be reinforced by a protective tube of steel. The protective effect favors the hardened cement paste used for anti-corrosion purposes in that it renders the head part more resistant to bending and limits deformations.

Depending on the stability of the substrate, the composite piles are made from GEWI steels or self-drilling anchors, e.g. system Ischebeck. Fig. 16 shows post foundations for different ground conditions, some of which are out of use now.

Only some systems from France get by without post foundations. The tubular posts standing downslope of the net plane are placed on the ground by means of special spiked foot plates and secured to the upslope anchors by means of ground ropes.

Back-anchoring of the posts

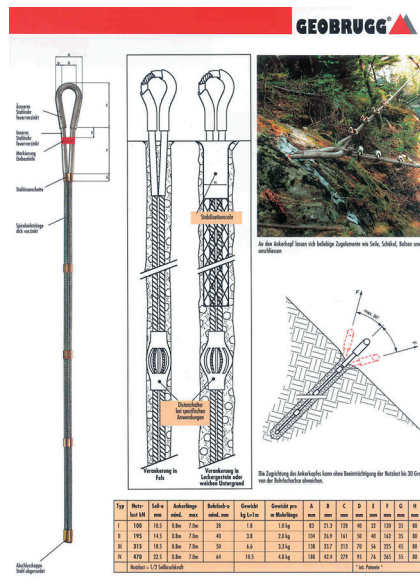

Fig. 17

Back-anchoring of the posts has also seen some development. Initially the posts were simply back-anchored upslope in the plane of the dip direction of the slope. In 1988, some manufacturers changed to the more stable back-anchoring by 2 ropes of V-shaped horizontal projection which was thus able to also cope with a force component occurring parallel to the plane of the fence. Depending on the system, one can now fully renounce on back-anchoring for energies below 300 kJ subject to suitable dimensioning of posts and anchors.

Initially the transfer of forces from anchor ropes into the ground was generally effected via slack rod anchors equipped with eyebolts, normally GEWI anchors manufactured as SN anchors. Rope anchors have been used in the majority since 1962. Due to their lack of bending resistance they provide the desired transfer without moments of forces acting in non-axis direction (Fig. 17). GEOBRUGG patented the rope anchor with loop tubes and double corrosion protection in the head part in 1993.

Distances between posts _____ In the original applications the distances between posts were still relatively small, at Brusio only 3 m, for example. By the end of the eighties, distances of 4 to 6 m between posts were common, except for the above mentioned Bannwald Altorf project, where the distance between the post was 10 m, already. It was in the course of the field tests of Beckenried in 1988 – 1991 that it became common that bigger distances between posts did not only reduce the probability of undesirable direct hits on posts and retaining ropes, but that they also made the systems more flexible which in turn resulted in higher energy absorptions. Since 1992 a distance between posts of 10 m is standard with GEOBRUGG, and by now also with most other systems. The bigger distances between posts also brought a reduction of the effort and expenses for posts and anchorages. However, to make higher energy absorptions at all possible in the first place, they also led to substantially bigger excursions of the nets of 50 to 60 % of the distance between the posts for the dimensioning impact. For this reason the structures had to be moved further away from the endangered objects. Where this is not feasible, the distances between posts must be reduced or further back-anchors must be provided.

Corrosion protection _____ Ropes, posts and connecting elements galvanized according to DIN 2078 were used right from the start. Under the trade name of Supercoating GEOBRUGG is offering systems with corrosion protection according to the Galfan process (Zn/Al process) since 1996. In this method the zinc is alloyed with 5 % of aluminium. According to independent opinions, e.g. of the EMPA, Swiss Federal Laboratories for Materials Testing and Research, this corrosion protection lengthens the useful life by a factor of approx. 3. It is recommended in particular where protective structures are exposed to the spray mists of salt used against icy roads or to particularly aggressive conditions for other reasons, e.g. along coasts.

Apart from the galvanizing, nets additionally coated with green anti-corrosion paint have also been used, particularly in the past.

Installation and maintenance _____ While the erection of a protective structure was a job for specialists at the outset, suitable installation aids and refined assembly instructions have simplified the work to an extent that, in simple terrain and with good access possibilities, an ordinary construction company is capable of installing a system on its own after brief instructions. This state is the result of a development also. The fences have been consisting of easy-mounting modular systems since 1991. The predecessors of GEOBRUGG, on the other hand, installed the majority of the systems with their own teams or supported the executing companies with permanently present technicians. It has been common to this day for a representative of the manufacturer to assist in the technical reception of the structures so that installation errors can be excluded.

The question of maintenance and of the connected expenses, important particularly where rockfall occurs at a higher frequency, has never been neglected in the course of developments. Reference is made to the measures taken in the interest of protecting the foundations and the convenient exchange of activated brake elements. Without rockfall strains up to the level of the dimensioning impact, the system requires no maintenance anyway. Considerable progress towards the minimization of maintenance costs was achieved with the dimensioning philosophy developed by DUFFY

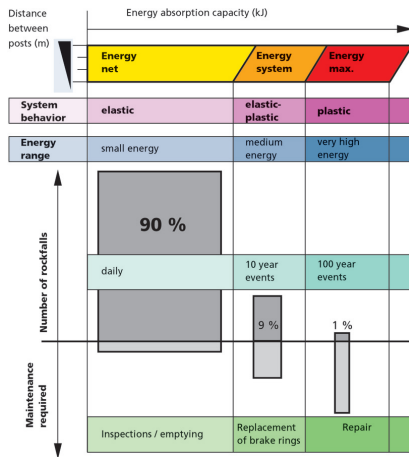

Fig. 18

& HALLER. This is based on categories of rockfall energy according to the frequency with which it occurs at the location in question, as shown in Fig. 18. Frequent events must not lead to damages to the system, 10-year events are allowed to strain the brake elements and only events of a recurrence probability of at least 50 years may cause damages requiring repair. Above this level is the dimensioning impact which must yet be coped with under acceptance of the inevitable serious damage.

The often prevailing problem of rockfall protection systems being erected in forests or along forest edges, and thus impairing effective forest management, has been countered by the development of systems which can simply be folded down.

In deciduous forests, however, clearing of the intercepting areas of branches and dead leaves every few years requires a maintenance effort which must not be underestimated. Rotting leaves lead to the formation of humic acids which strain the corrosion protection coating. Where low rockfall frequencies prevail, the elimination of storm damages from toppled trees may be considerably more expensive than the repair effort due to rockfall.

Special measures of a design nature for the removal of rocks from the intercepting areas are necessary in particular with fences of more than 2 m height, if tiresome lengthwise transport along the usually soon bush-clad terrain to the next interruption is to be avoided. After a suitable reduction of the blocks to a harmless size by means of the mechanical pick or if appropriate by drill and blast, a release of the net along the bottom or at the posts is helpful.

Field tests

On the drawing board alone the described development would hardly have been possible. A decisive factor for progress at GEOBRUGG was no doubt the experience which the employees in charge were able to gain from the fortunate combination of acquisition, technical consultancy, involvement in production, site supervision and development activity. This resulted in a perfect feedback from the otherwise usually separate individual tasks. It was supplemented by the vast in-house experience of a leading manufacturer of wire rope and, to a very major extent, by the systematic tests conducted at high expense and with scientific, meticulous precision on system components both in the own laboratory and on complete systems in the field.

The described tests at Brunnen/CH (1962), at the Lötschberg/CH (1968) and on the company's site at Birr/CH (from 1975) were followed for GEOBRUGG by the cooperation with the Californian Transportation Authority CALTRANS. The rock rolling tests on a hill of 35 m at Big Sur were carried out in 1989, then came the rock rolling tests of 1991 in the old quarry of Oberbuchsiten/CH and from that time on the throw tests in the quarry at Beckenried/CH. In 1997, almost parallel field tests were under way at Shayupin, Taiwan, and at Itsukaichi, Japan. Current drop tests have been in progress since April 2001 at the new test location of Walenstadt/CH, after - irony of fate - an acute danger of rockfall had delayed the site's completion by more than half a year.

Various European competitors saw the need to perform systematic tests including a Swiss Company in 1985 in a gravel pit in combination with a first supply contract. The trials were in the care of the Engineering Office HEIERLI of Zürich. Drop tests with a mass of 10 kN falling from a height of 20 m (200 kJ) were made. The tested system consisted of a net element tensioned in a steel frame of 5 x 5 m and equipped with 4 brake elements. The frame was placed over a pit. Plate brakes specially developed and optimized at the time were used, as they still are today. Similar drop tests over a pit were also made by FATZER AG, using the SIFA pipe brake ring in 1988.

According to information of GERBER (2001), a total of 343 tests have been conducted in Switzerland alone since 1987 on 7 different test setups (Beckenried, Oberbuchsitzen, Giswil, Trübbach, Lungern, Rüthi, and Walenstadt). The highest number per year was achieved in 1991 with 74 tests. Rolling tests were done at Beckenried exclusively, while drop tests were carried out at Rüthi and Walenstadt (at which location they continue). Aerial ropeways were installed on the remaining test sites for inclined throws.

GEOBRUGG and its predecessors influenced developments over these 43 years decisively. This is illustrated most impressively by the fact that the energy absorption rose from an initial 50 to 70 kJ to 3,000 kJ in this period. In other words, the energy absorption capacity has increased by a factor of about sixty. This is the dimension by which traffic routes, settlements and infrastructures secured by corresponding rockfall mitigation structures have in the meantime become safer. This fact alone would already be reason enough for the present festivities and for a general thank you very much addressed to all involved persons. The cost per meter of protective structure and per kJ have come down by an equal extent at the same time.

Energy absorption

Although they are all promoted under the term of rockfall protection fence and even if they are absorbing roughly the same amount of energy, the systems currently on the market vary considerably. This refers not least to the length of the braking distance, the braking forces that are generated and to the resulting forces to be taken up in the foundations and back anchors. Of greater consequence still is the different degree to which proofs are established, namely of the energy which the systems actually absorb under otherwise equal conditions, what the effects are in the foundations and back anchors, and how high the maintenance cost is.

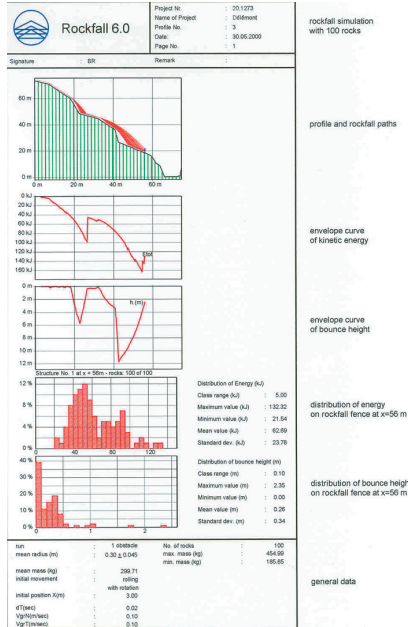

Fig. 19

The development of high-performance rockfall simulation programs set in in about 1980 and has become decisive for the dimensioning of the systems. Together with the indispensable geotechnical assessment, they permit to define the specific demands which the locations in question impose on the systems as far as height of the structure and energy absorption are concerned (Fig. 19). It was only on this basis that GEOBRUGG was able to develop its OPTUS dimensioning system which establishes a relation between the energy absorption of the nets and the frequency and energy of the rockfall events to be expected at the particular location in order to keep the maintenance effort at the minimum.

Standardization

For reasons of principle the standardization was unable to keep in step with the rapid development of the protection systems. Standardization, obviously, is only possible where a generally recognized state-of-the-art technology exists. While standards exist from other areas of technology for rope connections, steel construction components, wire ropes and corrosion protection by galvanizing, this is not the case for rockfall protection structures as systems. A start has meanwhile been made by the new edition of the Earthworks Regulations of the Deutsche Bahn AG, the Ril 836, which came into effect in December 1999. To date there are no general building supervisory approvals for rockfall protection systems in force, either, and the authors are not aware of any individual approvals as might be granted by the building supervision authorities of the states of Germany or the railways authority. Only few of the systems on the market are able to refer to tests monitored and evaluated by independent institutions (SPANG, 2000). Many suppliers are very reluctant to publish information on their tests, the brochures of the companies concerned are not freely available and if not really meaningful. This is why clients are often faced with the problem of having to decide between different systems without standardized or fixed criteria, except for the price which is unsuitable for the purpose.

This is not the only reason why the Working Group of the EOTA founded in 2000 and the test stand set up for certification tests on the Walensee in the context of the Swiss guideline of the SAEFL enforced in June 2001 represent a major step forward. The drop test facility enables clearly defined, reproducible and thus comparable tests for the different bidders and systems. The tests are supervised by the Federal Institute for Forest, Snow and Landscape Research and the test program follows the afore-mentioned guideline. The intended certification according to uniform criteria, however, is a result of the smallest common denominator. One has to accept for economical reasons that not all desirable test variants can be demanded.

With a view to the further development of rockfall protection systems with yet higher energies it is the authors' hope that the drop tests without spin and exclusively into the center of the panel are not the end of a testing practice which provided surprising insights in the past, especially in the case of rolling tests with spin and inclined throw tests. High angular velocities lead to a higher loss of usable residual height. From experience, high angular velocities can lead to a behavior similar to that of a circular saw, particularly in the case of plate-like, sharp-edged rockfall, and to failures clearly below the design energies. Hits in the corners or along the boundaries cause smaller energy absorptions than in the middle of the panel. Hits on retention ropes can endanger the overall stability of some systems. Desirable would be rolling tests and/or tests from the inclined throw with prior ground contact or also drop tests in which the block is given spin by ropes wound over its circumference, and a distribution of the impact points over the entire exposed system.

A suitable certificate confirming compatibility with the environment would also be useful for deployments under the ever more stringent environment protection regulations.

Low-energy systems

The market for low-energy systems, interestingly enough, did not remain unaffected by the described development, either. At the outset this segment of the market was primarily occupied by sleeper walls, but is now also a domain of constructions from steel wire nets (ring nets, diagonal wire rope nets, steel wire meshes). For reasons of landscape preservation and very much of costs, sleeper walls and similar massive constructions are now only used in exceptional cases any more. This is why, for energy absorptions up to 3,000 kJ, rockfall protection fences of steel wire nets meet all requirements specified for an approved, safe, economically efficient and ecologically compatible protection system.

Prospects

Rockfall protection systems are now used all over the world. Where this is not the case, it is usually the social circumstances that are not yet mature for them. Step by step this will no doubt also change in the poorer countries, with the result that the market for rockfall protection fences will develop positively also in future.

Those involved concur with the opinion that the energy absorption of 3,000 kJ achieved a few weeks ago is a milestone, but not the end of the development by far. Without wanting to be a prophet, it appears that 5,000 kJ will also be feasible in the years ahead. Attempts at a numerical calculation of the systems, a project initiated by GEOBRUGG, have been under way for some time and the envisaged research projects at a national and European level give rise to the expectation that the costly testing and optimizing in tests on scale 1:1 can receive at least calculatory support within a few years. Hereby it seems mandatory that the influence of the rotational energy, always present in nature, is included in the calculation.

Over the last years, steel wire nets have found access to other application areas apart from rockfall protection. Some of these are likely to achieve similar ranks on importance in future. They are, in detail:

- Slope and rockface covers;
- Applications for rockfall prevention purposes;
- Applications to protect against wet land slides;
- Protection from falling timber and ice;
- Protection on blasting;
- Prevention of terrorism / object protection.

Acknowledgement

The two authors of the contribution to this festive event have accompanied rockfall protection for a considerable stretch, Mr. Bolliger in a decisive position at Kabelwerke Brugg AG from 1960 to 1990. Various patents are also connected to his name. - Since his initial topical presentation at the world's first conference on rockfall mitigation organized by the UIC at Kandersteg in 1979, the first-mentioned author made various contributions to the development in his capacity as planner, client and independent consultant in a fair and open exchange of experiences. Both of them thank Fatzer AG GEOBRUGG and their predecessor, Kabelwerke Brugg AG, for the jointly covered stretch of the road. The first author expresses his thanks in particular to Mr. Commissaris and to his friends Bernhard Eicher and Bruno Haller, for enabling him to actively participate in many highlights of the described development, especially the tests in California, Oberbuchsitzen, Japan and Taiwan, and for the trusting business relationship in the rockfall simulation. Both of them extend their very best wishes for the next 50 years of rockfall and slope protection.

Literature

- AHLBURG, (1870): Der Straßenbau mit Einschluß der Construction der Strassenbrücken; Lehrbuch für den Unterricht an technischen Lehranstalten, sowie zum Selbststudium für Strassenbau- Ingenieure.- Braunschweig.
- HALLER, B.(1996): Merkmale moderner Steinschlagschutzsysteme und deren Dimensionierung.- Techn. Akad. Esslingen
- HEIERLI, W. (1976): Schutz gegen Felssturz und Steinschlag mit Drahtseilnetzen, Bern.
- JOHN, K.W. & SPANG, R.M. (1979):Steinschläge und Felsstürze – Voraussetzungen – Mechanismen – Sicherungen.- UIC Tag. Schutz der Bahnanlagen gegen Steinschlag u. Felssturz, Schlußbericht, Kandersteg.
- ROCHET, L.(1979): Protection contre les éboulements rocheux par filets métalliques.- Bull. Liaison Labo P. et Ch, 101, 21 – 27.
- SPANG, R.M. (2000): Standardisierung von Prüfverfahren für Steinschlagschutzbarrieren – Ziele und aktueller Stand.- Techn. Akad. Esslingen, 2. Kolloquium Bauen in Boden und Fels, 18. – 19. Jan. 2000.

Illustrations

- 1 Rockfall protection gallery according to AHLBURG (1870).
- 2 Avalanche prevention nets on Matthorn Pilatus, approx. 1963.
- 3 Avalanche prevention net, single section with timber frame.
- 4 Rockfall event on an avalanche prevention structure on the Stotzigberg, Vasön, Ct. St. Gallen / Switzerland, 1961.
- 5 Rockfall tests at Brunnen / CH, 1962.
- 6 Rigid rockfall protection system by a steel structure with deposit of old tires near Matsubarako, Nagano Prefecture, Japan.
- 7 Free-fall tests at Birr / CH, 1975.
- 8 Patent for the brake element of Kabelwerke Brugg AG of 1975.
- 9 Plate brake from France 1979.
- 10 Brake element from Italy
- 11 Brake ring of GEOBRUGG, before and after strain.
- 12 Ring net structure of GEOBRUGG in the Via Mala, 1996.
- 13 Rockfall tests on the Lötschberg South Ramp, 1968.
- 14 Rope guidance in the protection system of Fatzer AG, before 1993.
- 15 Avalanche prevention structure Matthorn Pilatus, approx. 1963, post with cardan joint.
- 16 Post foundation systems GEOBRUGG.
- 17 Rope anchor system GEOBRUGG.
- 18 Dimensioning approach OPTUS® of GEOBRUGG.
- 19 Rockfall simulation with ROCKFALL 6.0, Dr. SPANG Ltd.

